

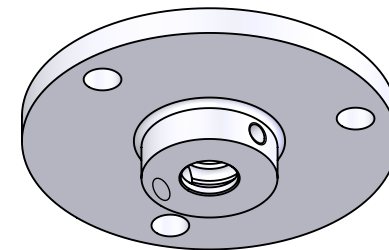

A-A
SCALE 1 : 2

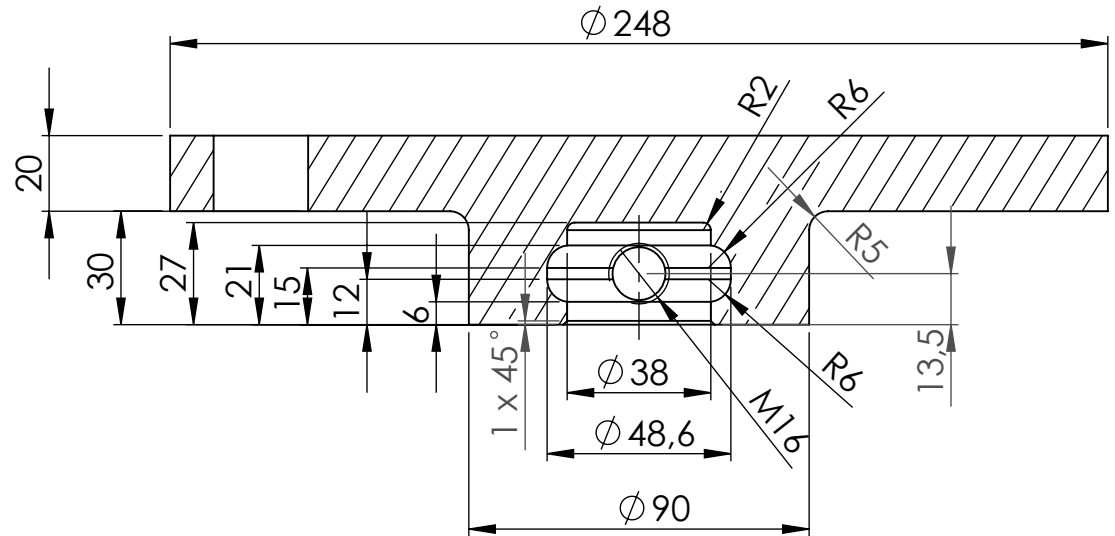

Tolerances: $\pm 0,1$

Description: Top w. mounting plate for DMC 150				Drawing no.: Top w mount pl for DMC 150		Part rev.:		Drawing rev.: 1	
Sign.:	LF	Drawn date:	15-08-2019	Weight:	8.7 kg.	Scale:	1:3	A4	
Rev. sign:	FJE	Rev. date:	04-05-2023						
Material: AISI 316		Ordre: 101-7 DLC		  <p>The Weighing Experts</p>					
Approved by:		Appr. date:							
<small>Dimension without tolerance, follows DS/ISO 2768-m This drawing is the property of Eilersen Industrial Sensors, and is not to be copied or shown to third parties.</small>									